

Description

BP3336D is a high PF PSR constant current LED driver with high current accuracy. It is integrated with 650V MOSFET and is suitable for 90Vac-277Vac universal input.

BP3336D realizes high PF by constant on time control. With internal THD optimizer, the THD of input current can be lower than 15% under universal input. BP3336D works in BCM mode, which can help to improve switching loss and EMI performance.

With internal HV start up and fast start up control, BP3336D can build up output current within 500ms.

With internal line and load compensation, BP3336D can achieve excellent line and load regulation.

BP3336D can work as floating buck-boost with single-winding inductor or isolated Flyback topology with two or three windings transformer.

BP3336D is available in SOP-8 package



SOP-8 Package

Features

- 90-277Vac universal input
- High PF low THD (PF>0.9, THD<15%)
- Support two-winding for isolated application
- Build in HV start up, start up time <500mS
- High precious current reference (+/-3%)
- Good line and load regulation
- Critical conduction mode
- Low operation current
- VCC UVLO
- Cycle by cycle current limitation
- Output open/short protection
- Thermal fold back
- SOP-8 package

Applications

- External LED driver
- LED Lamps

Typical Application

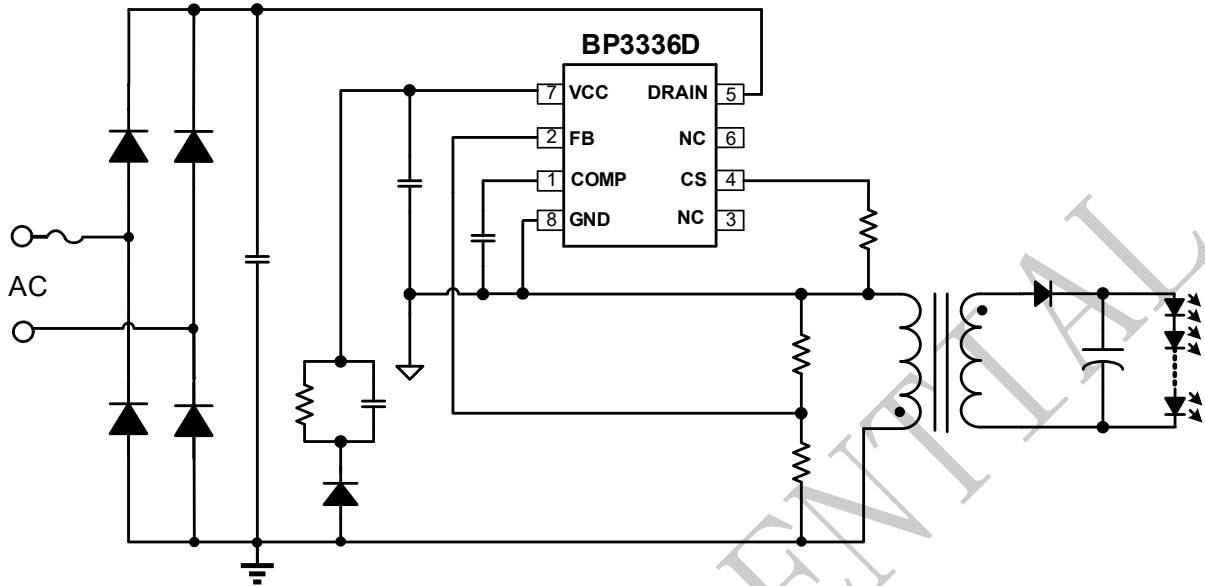

Figure 1 Floating isolated application with two-winding transformer

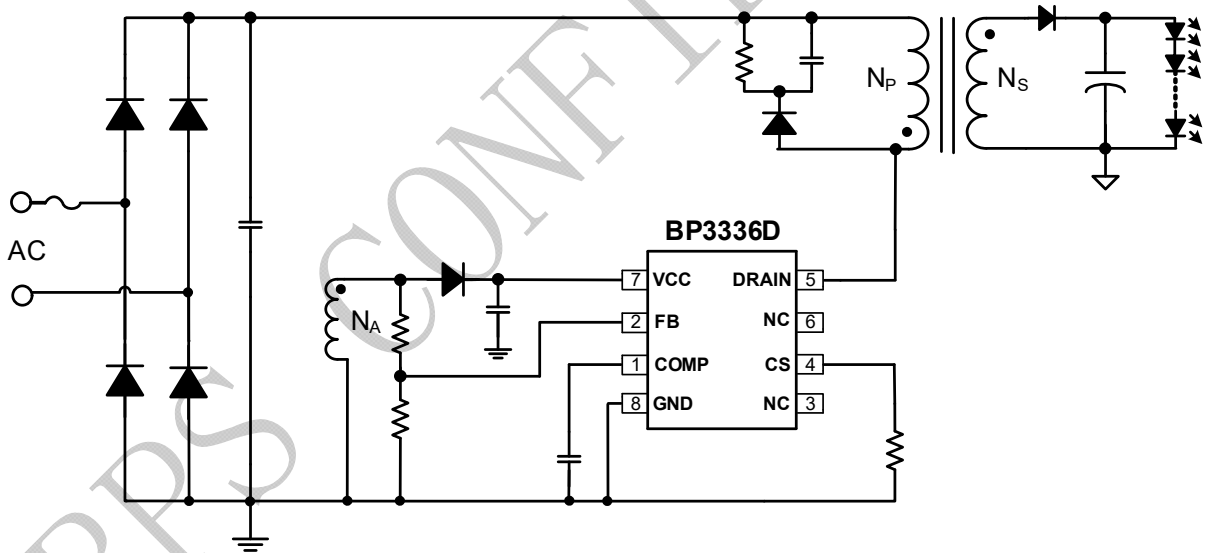

Figure 2 Grounded isolated application with Three-winding transformer

Disclaimer

The information provided in this datasheet is believed to be accurate and reliable. However, Bright Power Semiconductor (BPS) reserves the right to make changes at any time without prior notice.

No license, to any intellectual property right owned by BPS or any other third party, is granted under this document. BPS provides information in this datasheet “AS IS” and with all faults, and makes no warranty, express or implied, including but not limited to, the accuracy of the information provided in this datasheet, merchantability, fitness of a specific purpose, or non-infringement of intellectual property rights of BPS or any other third party. BPS disclaims any and all liabilities arising out of this datasheet or use of this datasheet, including without limitation consequential or incidental damages.

BPS Confidential