

PRIMARY SIDE CONTROL IC FOR OFF-LINE BATTERY CHARGERS AP3706**General Description**

The AP3706 is a high performance AC/DC power supply controller for battery charger and adapter applications. The device uses Pulse Frequency Modulation (PFM) method to build discontinuous conduction mode (DCM) flyback power supplies.

The AP3706 provides constant voltage, constant current (CV/CC) regulation without requiring an opto-coupler and secondary control circuitry. It also eliminates the need of loop compensation circuitry while maintaining stability.

The AP3706 achieves excellent regulation and high power efficiency, the no-load power consumption is less than 200mW at 265VAC input.

The AP3706 is available in SOIC-8 and DIP-8 packages.

Features

- Primary Side Control for Rectangular Constant Current and Constant Voltage Output
- Eliminates Opto-Coupler and Secondary CV/CC Control Circuitry
- Eliminates Control Loop Compensation Circuitry
- Flyback Topology in DCM Operation
- Random Frequency Modulation to Reduce System EMI
- Valley Turn on of External Power NPN Transistor
- Built-in Soft Start
- Open Circuit Protection
- Over Voltage Protection
- Short Circuit Protection

Applications

- Adapters/Chargers for Cell/Cordless Phones, PDAs, MP3 and Other Portable Apparatus
- Standby and Auxiliary Power Supplies

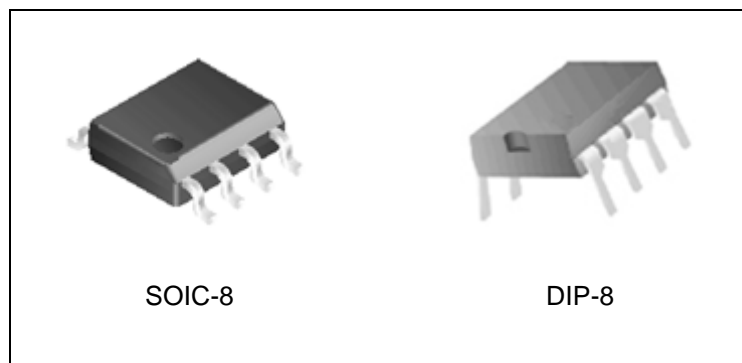

Figure 1. Package Types of AP3706

PRIMARY SIDE CONTROL IC FOR OFF-LINE BATTERY CHARGERS AP3706

Pin Configuration

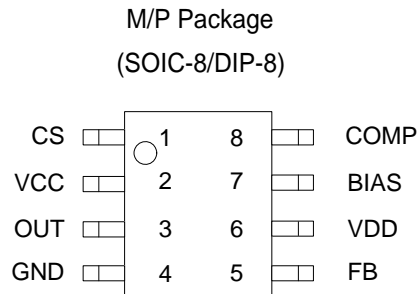

Figure 2. Pin Configurations of AP3706 (Top View)

Pin Description

Pin Number	Pin Name	Function
1	CS	The primary current sense
2	VCC	Supply voltage
3	OUT	This pin drives the base of external power NPN switch
4	GND	Ground
5	FB	The voltage feedback from the auxiliary winding
6	VDD	The 5V output of the internal voltage regulator
7	BIAS	This pin sets the bias current inside AP3706 with an external resistor to GND
8	COMP	This pin connects a bypass capacitor for CC function



PRIMARY SIDE CONTROL IC FOR OFF-LINE BATTERY CHARGERS AP3706

Functional Block Diagram

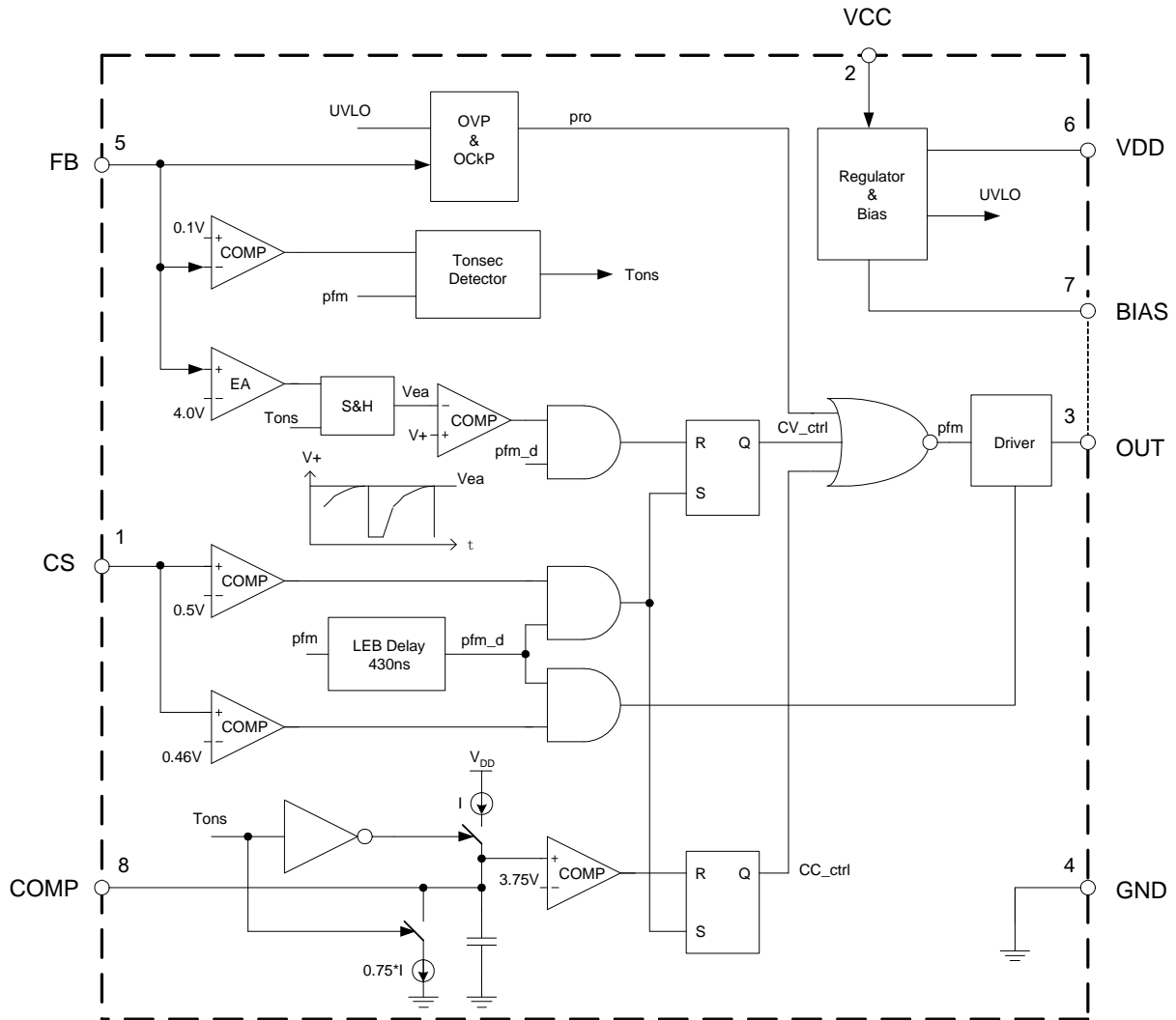
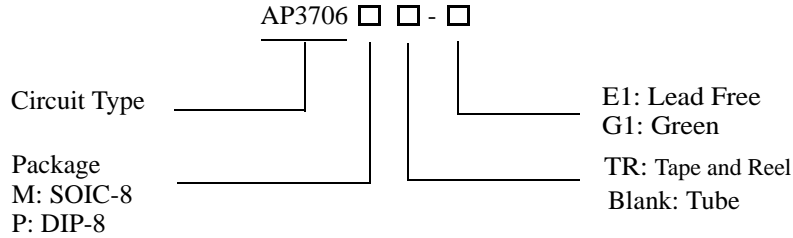

Figure 3. Functional Block Diagram of AP3706



PRIMARY SIDE CONTROL IC FOR OFF-LINE BATTERY CHARGERS AP3706

Ordering Information



Package	Temperature Range	Part Number		Marking ID		Packing Type
		Lead Free	Green	Lead Free	Green	
SOIC-8	-40 to 85°C	AP3706M-E1	AP3706M-G1	3706M-E1	3706M-G1	Tube
		AP3706MTR-E1	AP3706MTR-G1	3706M-E1	3706M-G1	Tape & Reel
DIP-8		AP3706P-E1	AP3706P-G1	AP3706P-E1	AP3706P-G1	Tube

BCD Semiconductor's Pb-free products, as designated with "E1" suffix in the part number, are RoHS compliant. Products with "G1" suffix are available in green packages.

Absolute Maximum Ratings (Note 1)

Parameter	Value	Unit
Supply Voltage VCC	-0.3 to 30	V
Voltage at CS, BIAS, OUT, VDD, COMP to GND	-0.3 to 7	V
FB input (Pin 5)	-40 to 10	V
Output Current at OUT	Internally limited	A
Power Dissipation at T _A =25°C	0.657	W
Operating Junction Temperature	150	°C
Storage Temperature	-65 to 150	°C
Lead Temperature (Soldering, 10s)	300	°C
Thermal Resistance Junction-to-Ambient	190	°C/W
ESD (Machine Model)	200	V

Note 1: Stresses greater than those listed under "Absolute Maximum Ratings" may cause permanent damage to the device. These are stress ratings only, and functional operation of the device at these or any other conditions beyond those indicated under "Recommended Operating Conditions" is not implied. Exposure to "Absolute Maximum Ratings" for extended periods may affect device reliability.



PRIMARY SIDE CONTROL IC FOR OFF-LINE BATTERY CHARGERS AP3706

Electrical Characteristics

($V_{CC}=15V$, $T_A=25^{\circ}C$, unless otherwise specified.)

Parameter	Symbol	Conditions	Min	Typ	Max	Unit
UVLO SECTION						
Start-up Threshold	$V_{TH(ST)}$		17	18.5	20	V
Minimal Operating Voltage	$V_{OPR(min)}$	After turn on	6.5	7.3	8.1	V
REFERENCE VOLTAGE SECTION						
BIAS Pin Voltage	V_{BIAS}	$R_{BIAS}=200k\Omega$ Before turn on	1.170	1.205	1.240	V
VDD Pin Voltage	VDD		4.75	5.0	5.25	V
STANDBY CURRENT SECTION						
Start-up Current	I_{ST}	$V_{CC} = V_{TH(ST)}-0.5V$, $R_{BIAS}=200k\Omega$, Before turn on		70	80	μA
Operating Current	$I_{CC(OPR)}$	$R_{BIAS}=200k\Omega$		680	900	μA
DRIVE OUTPUT SECTION						
OUT Maximum Current	Sink	I_{OUT}	$R_{BIAS}=200k\Omega$	50		mA
	Source			25	30	
CURRENT SENSE SECTION						
Current Sense Threshold	V_{CS}		490	510	530	mV
Pre-Current Sense	$V_{CS(PRE)}$		440	460	480	mV
Leading Edge Blanking				430		ns
FEEDBACK INPUT SECTION						
Feedback Pin Input Leakage Current	I_{FB}	$V_{FB}=4V$	10.0	12.5	15.0	μA
Feedback Threshold	V_{FB}		3.90	4.00	4.10	V
Enable Turn-on Voltage	$V_{FB(EN)}$		-0.9	-0.7	-0.5	V
COMP THRESHOLD VOLTAGE SECTION						
Turn-on Threshold Voltage	V_{COMP}		3.42	3.60	3.78	V
PROTECTION SECTION						
Over Voltage Protection	$V_{FB(OVP)}$		7	8	9	V



PRIMARY SIDE CONTROL IC FOR OFF-LINE BATTERY CHARGERS AP3706

Typical Performance Characteristics

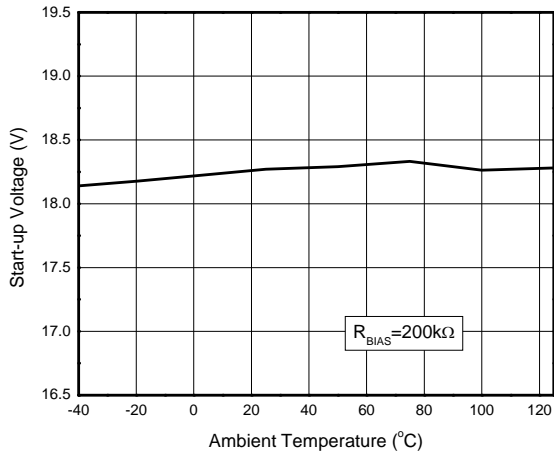

Figure 4. Start-up Voltage vs. Ambient Temperature

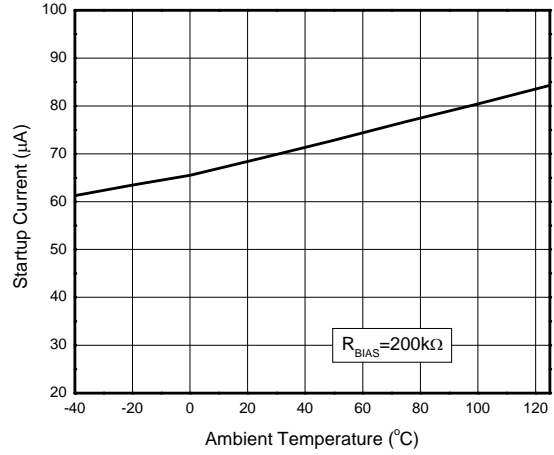

Figure 5. Start-up Current vs. Ambient Temperature

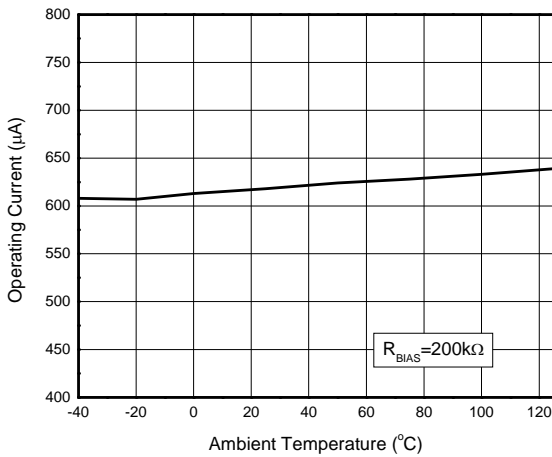

Figure 6. Operating Current vs. Ambient Temperature

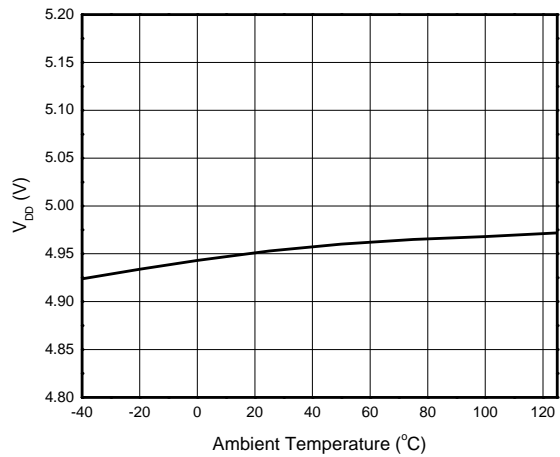

Figure 7. V_{DD} vs. Ambient Temperature



PRIMARY SIDE CONTROL IC FOR OFF-LINE BATTERY CHARGERS AP3706

Typical Performance Characteristics (Continued)

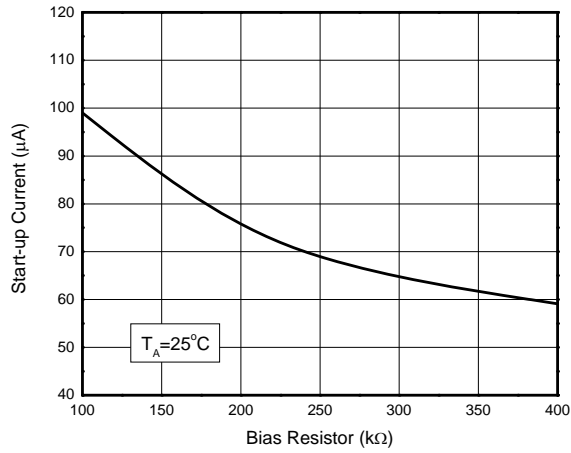

Figure 8. Start-up Current vs. Bias Resistor

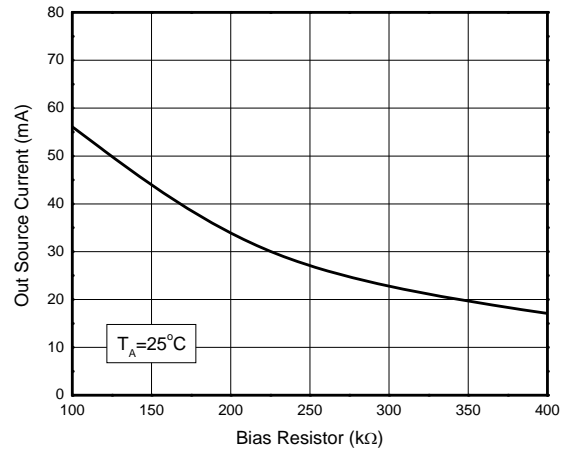

Figure 9. OUT Source Current vs. Bias Resistor

PRIMARY SIDE CONTROL IC FOR OFF-LINE BATTERY CHARGERS AP3706

Operation Description

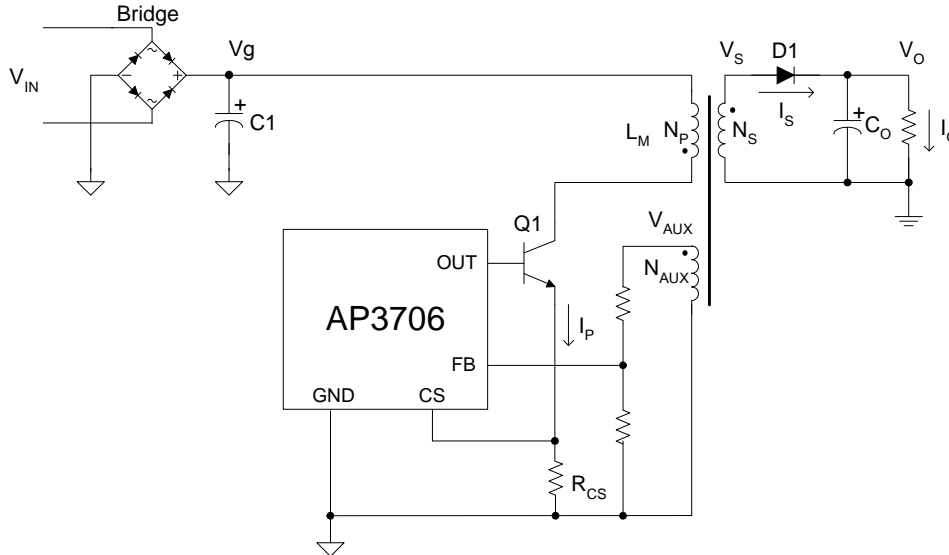

Figure 10. Simplified Flyback Converter Controlled by AP3706

Figure 10 illustrates a simplified flyback converter controlled by AP3706.

The energy stored in the magnetizing inductance LM each cycle is therefore:

Constant Primary Peak Current

The primary current ip(t) is sensed by a current sense resistor R_{CS} as shown in Figure 10.

$$Eg = \frac{1}{2} \times L_M \cdot I_{pk}^2 \quad \dots\dots\dots(3)$$

The current rises up linearly at a rate of:

So the power transferring from the input to the output is given by:

$$\frac{dip(t)}{dt} = \frac{vg(t)}{L_M} \quad \dots\dots\dots(1)$$

$$P = \frac{1}{2} \times L_M \times I_{pk}^2 \times f_{sw} \quad \dots\dots\dots(4)$$

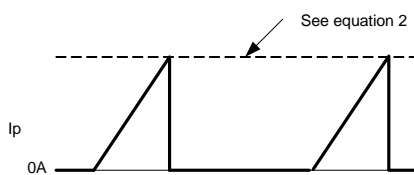

Figure 11. Primary Current Waveform

As illustrated in Figure 11, when the current ip(t) rises up to Ipk, the switch Q1 turns off. The constant peak current is given by:

Where the fsw is the switching frequency. When the peak current Ipk is constant, the output power depends on the switching frequency fsw.

$$I_{pk} = \frac{V_{CS}}{R_{CS}} \quad \dots\dots\dots(2)$$

Constant Voltage Operation

The AP3706 captures the auxiliary winding feedback voltage at FB pin and operates in constant-voltage (CV) mode to regulate the output voltage. Assuming the secondary winding is master, the auxiliary winding is slave during the D1 on-time. The auxiliary voltage is given by:

$$V_{AUX} = \frac{N_{AUX}}{N_S} \times (V_o + V_d) \quad \dots\dots\dots(5)$$

PRIMARY SIDE CONTROL IC FOR OFF-LINE BATTERY CHARGERS AP3706

Operation Description (Continued)

Where the V_d is the diode forward drop voltage.

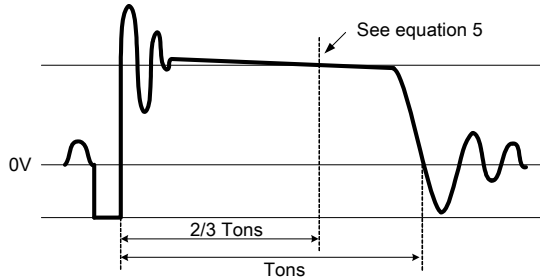

Figure 12. Auxiliary Voltage Waveform

The output voltage is different from the secondary voltage in a diode forward drop voltage. The diode drop voltage depends on the current. If the secondary voltage is always detected at a constant secondary current, the difference between the output voltage and the secondary voltage will be a fixed V_d . The voltage detection point is at two-thirds of the D1 on-time. The CV loop control function of AP3706 then generates a D1 off-time to regulate the output voltage.

Constant Current Operation

The AP3706 is designed to work in constant-current (CC) mode. Figure 13 shows the secondary current waveforms.

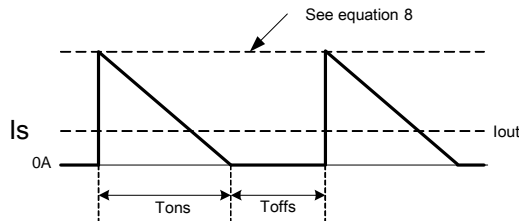

Figure 13. Secondary Current Waveform

In CC operation, the CC loop control function of AP3706 will keep a fixed proportion between D1 on-time T_{ons} and D1 off-time T_{offs} by discharging or charging the capacitance connected in COMP pin. The fixed proportion is

$$\frac{T_{ons}}{T_{offs}} = \frac{4}{3} \dots\dots\dots(6)$$

The relationship between the output constant-current and secondary peak current I_{pks} is given by:

$$I_{out} = \frac{1}{2} \times I_{pks} \times \frac{T_{ons}}{T_{ons} + T_{offs}} \dots\dots\dots(7)$$

At the instant of D1 turn-on, the primary current transfers to the secondary at an amplitude of:

$$I_{pks} = \frac{N_p}{N_s} \times I_{pk} \dots\dots\dots(8)$$

Thus the output constant-current is given by:

$$I_{out} = \frac{1}{2} \times \frac{N_p}{N_s} \times I_{pk} \times \frac{T_{ons}}{T_{ons} + T_{offs}} = \frac{2}{7} \times \frac{N_p}{N_s} \times I_{pk} \dots\dots\dots(9)$$

Leading Edge Blanking

When the power switch is turned on, a turn-on spike will occur on the sense-resistor. To avoid false-termination of the switching pulse, a 430ns leading-edge blanking is built in. During this blanking period, the current sense comparator is disabled and the gate driver can not be switched off.

CCM Protection

The AP3706 is designed to operate in discontinuous conduction mode (DCM) in both CV and CC modes. To avoid operating in continuous conduction mode (CCM), the AP3706 detects the falling edge of the FB input voltage on each cycle. If a 0.1V falling edge of FB is not detected, the AP3706 will stop switching.

OVP & OCKP

The AP3706 includes output over-voltage protection (OVP) and open circuit protection (OCKP) circuitry as shown in Figure 14. If the voltage at FB pin exceeds 8V, 100% above the normal detection voltage, or the -0.7V falling edge of the FB input can not be monitored, the AP3706 will immediately shut off and enters hiccup mode. The AP3706 sends out a fault detection pulse every 8ms in hiccup mode until the fault has been removed.

PRIMARY SIDE CONTROL IC FOR OFF-LINE BATTERY CHARGERS AP3706

Operation Description (Continued)

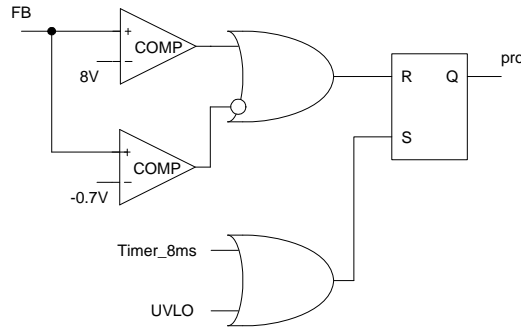

Figure 14. OVP and OCKP Function Block

Typical Application

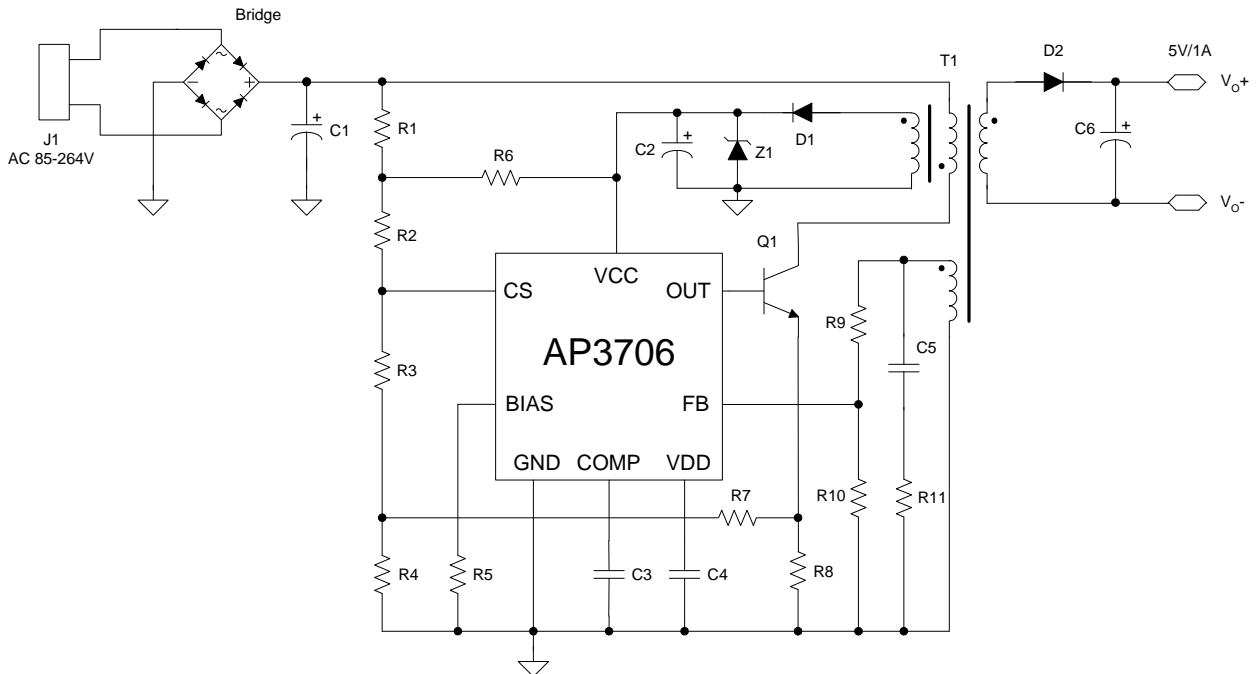

Figure 15. 5V/1A Output for Battery Charger of Mobile Phone



PRIMARY SIDE CONTROL IC FOR OFF-LINE BATTERY CHARGERS AP3706

Mechanical Dimensions

SOIC-8

Unit: mm(inch)

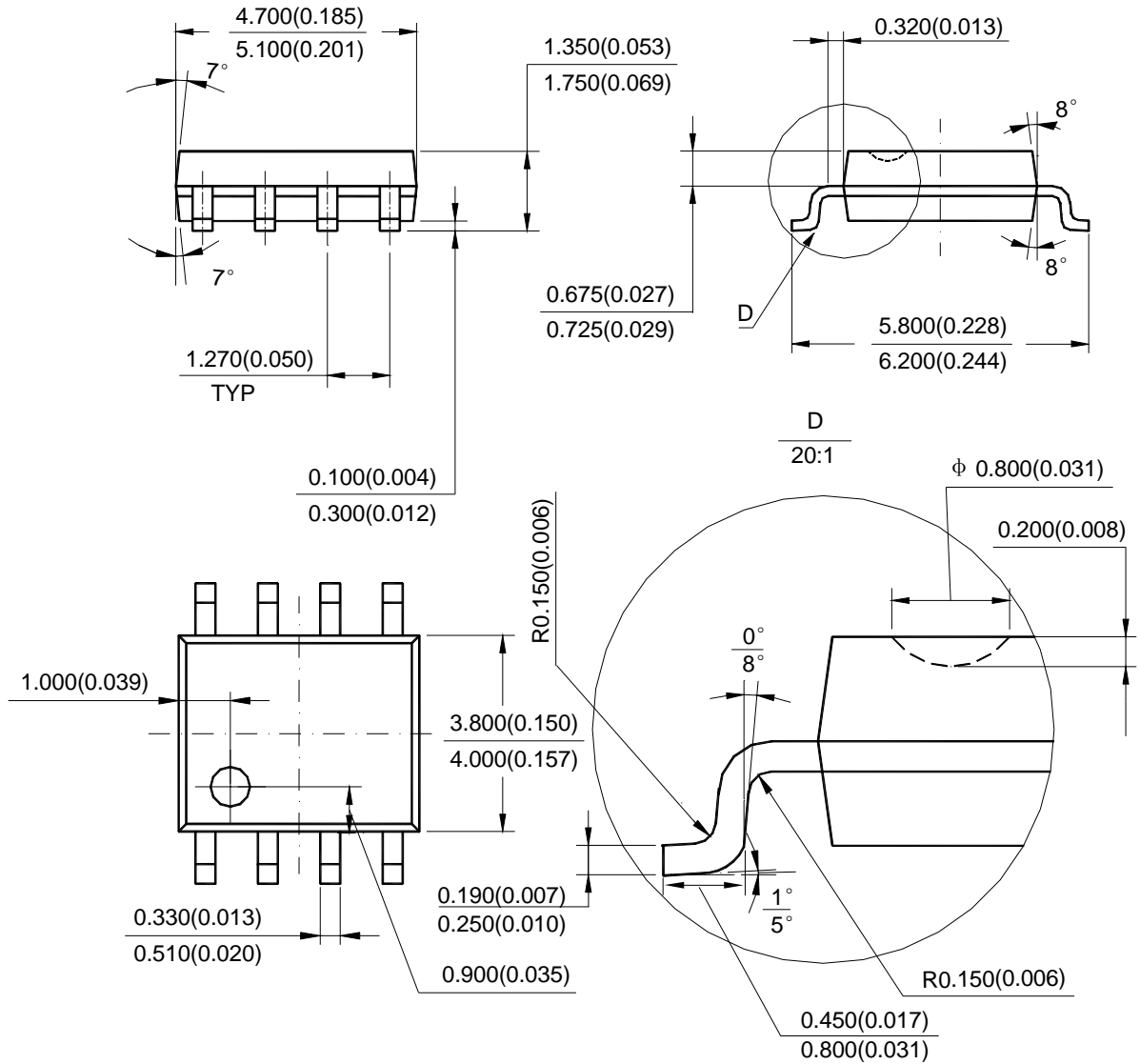



PRIMARY SIDE CONTROL IC FOR OFF-LINE BATTERY CHARGERS AP3706

Mechanical Dimensions (Continued)

DIP-8

Unit: mm(inch)

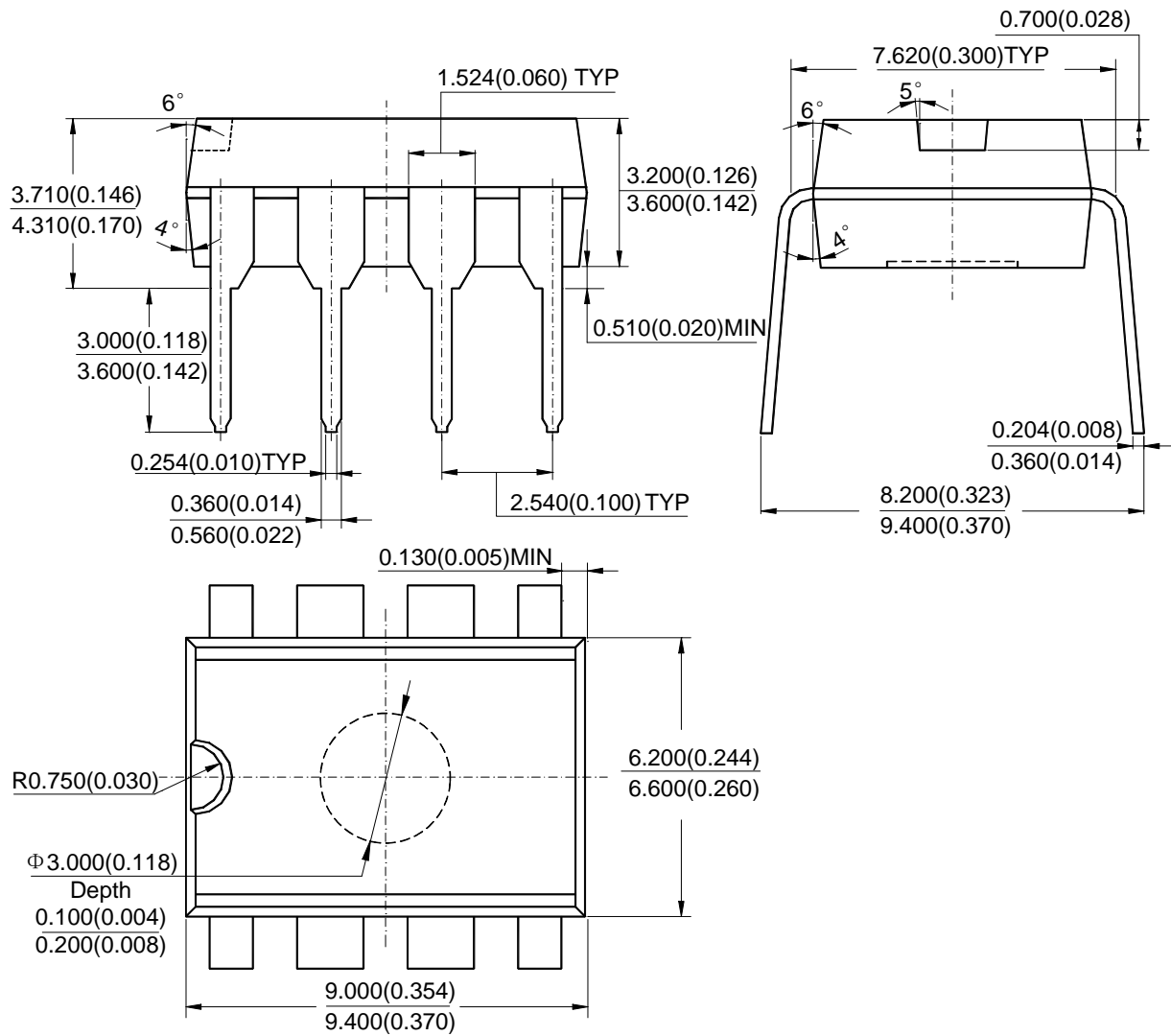



BCD Semiconductor Manufacturing Limited

<http://www.bcdsemi.com>

IMPORTANT NOTICE

BCD Semiconductor Manufacturing Limited reserves the right to make changes without further notice to any products or specifications herein. BCD Semiconductor Manufacturing Limited does not assume any responsibility for use of any its products for any particular purpose, nor does BCD Semiconductor Manufacturing Limited assume any liability arising out of the application or use of any its products or circuits. BCD Semiconductor Manufacturing Limited does not convey any license under its patent rights or other rights nor the rights of others.

MAIN SITE

- Headquarters

BCD Semiconductor Manufacturing Limited

No. 1600, Zi Xing Road, Shanghai Zizhu Science-based Industrial Park, 200241, China
Tel: +86-21-24162266, Fax: +86-21-24162277

- Wafer Fab

Shanghai SIM-BCD Semiconductor Manufacturing Co., Ltd.

800 Yi Shan Road, Shanghai 200233, China
Tel: +86-21-6485 1491, Fax: +86-21-5450 0008

REGIONAL SALES OFFICE

Shenzhen Office

Shanghai SIM-BCD Semiconductor Manufacturing Co., Ltd., Shenzhen Office
Room E, 5F, Noble Center, No.1006, 3rd Fuzhong Road, Futian District, Shenzhen,
518026, China
Tel: +86-755-8826 7951
Fax: +86-755-8826 7865

Taiwan Office

BCD Semiconductor (Taiwan) Company Limited
4F, 298-1, Rui Guang Road, Nei-Hu District, Taipei,
Taiwan
Tel: +886-2-2656 2808
Fax: +886-2-2656 2806

USA Office

BCD Semiconductor Corp.
30920 Huntwood Ave. Hayward,
CA 94544, USA
Tel : +1-510-324-2988
Fax: +1-510-324-2788